

# PTZ Dome Wall Mount WE45-A



## Specifications

| Bracket     | WE45-A   |
|-------------|--|
| Application | Indoor or outdoor, wall installation for PTZ dome camera |
| Dimensions  | 216mmx141mmx314mm (8.5" x 5.6" x 12.4")                  |
| Weight      | 1.0kg(2.2lb)   |
| Material    | Aluminum alloy   |

## Dimensions

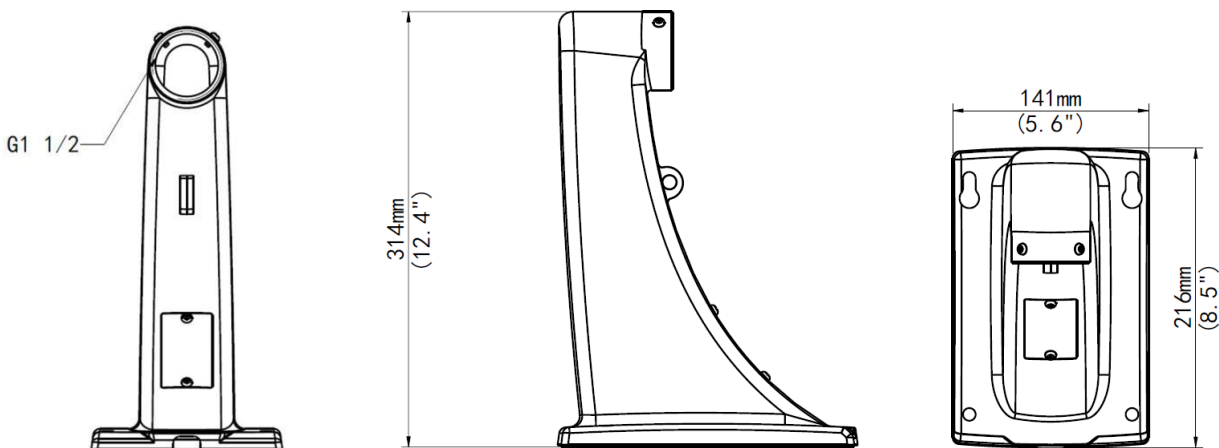

### Petawise Inc.

Unit 8-9, 1040 Martin Grove Road, Etobicoke, Ontario, Canada M9W 4W1  
 Sales@petawise.com; Marketing@petawise.com  
 www.petawise.com

*\*Product specifications and availability are subject to change without notice.*